

7055 Taschereau
 Brossard, QC J4Z 1A7
LOCAL 175

SUPERFICIE LOCATIVE

Boma 6991 pi.ca.
 Terrasse N/A

Total 6991 pi.ca.

ÉCHELLE

1/16-" = 1'-0"

VERSION

24 / 04 / 2024

PLAN CLÉ - 3e ÉTAGE

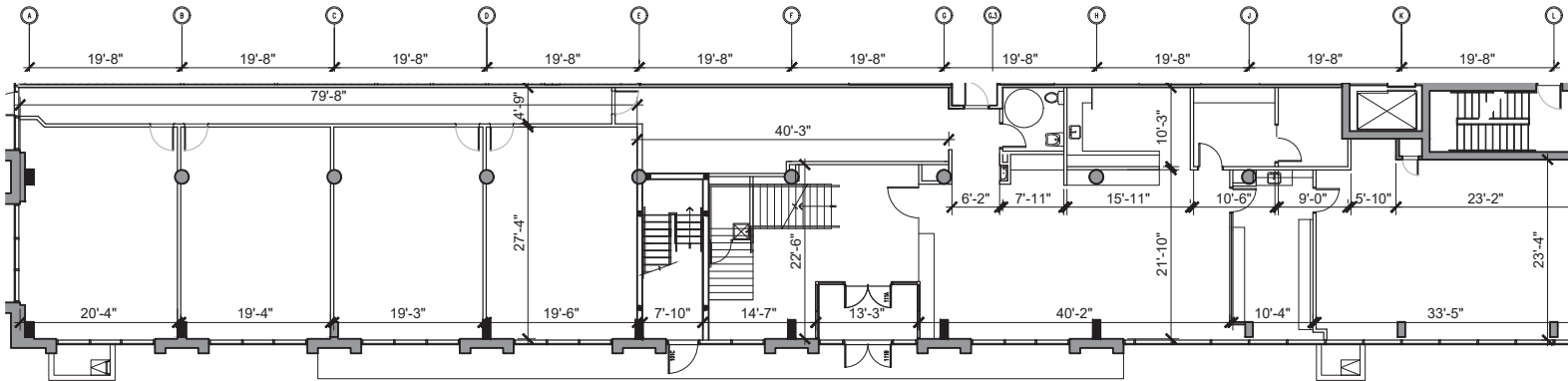
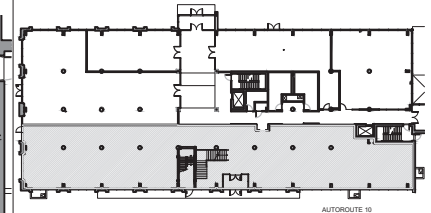

LES DIMENSIONS SONT SUJETS À CHANGEMENT
 SANS PRÉAVIS.

POUR IMPRESSION SUR FORMAT 11X17



7055 Boul. Taschereau, bureau 640
 Brossard, Québec,
 J4Z 1A7

450-678-9821
 Location@iwp.ca
 www.iwp.ca